

# RLSERIES | Rotary Airlock Valves

SIMPLE, STABLE AND ECONOMICAL AIRLOCKS

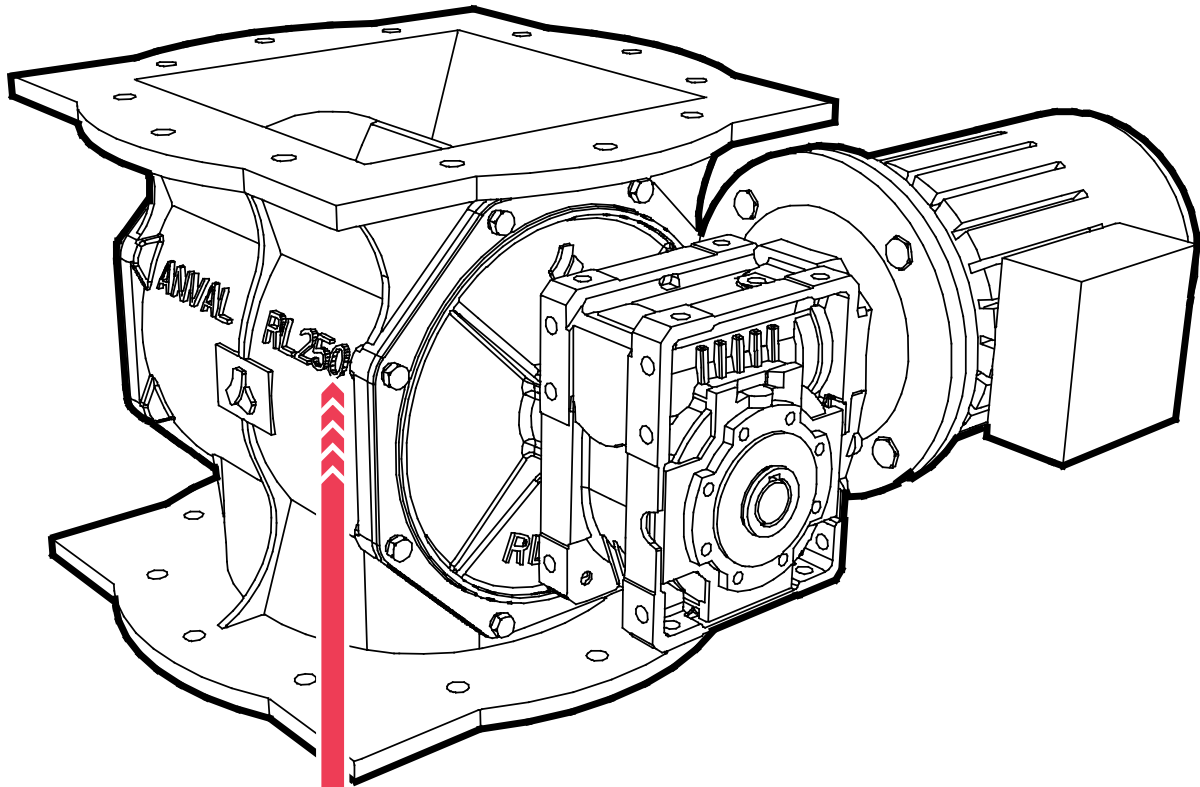

- ROBUST DESIGN
- HIGH PERFORMANCE DRIVE
- NO COMPLEX ADJUSTMENTS
- MINIMUM MAINTENANCE REQUIREMENTS
- HEAVY-DUTY SEALING CAPACITY
- AVAILABLE IN DIRECT / CHAIN DRIVE TYPES
- EXCELLENT AIR LOCK PERFORMANCE
- COST EFFECTIVE
- UNIVERSAL SQUARE FLANGE

# RLSERIES | Rotary Airlock Valves

SIMPLE, STABLE AND ECONOMICAL AIRLOCKS

Anval has an extensive range of feeders & airlocks used in a wide range of applications from heavy minerals industries to light agricultural applications.

The RL range of valves are available in opening sizes from 150mm - 300mm. Unlike our competitors, the RL valve bodies are fully cast in a single piece reducing the number of seams for wear. In addition, as all of the components are manufactured from cast iron the valve has all of the advantages of cast iron over traditional mild steel including superior corrosion resistance, better wear properties and thermal stability.

Being a customer centric organization, Anval believes in providing high quality, customized products and services to facilitate customer's business model in all possible ways.

The simplicity of the Anval designs means a relatively low maintenance requirement even under harsh operating conditions such as mining and heavy industry.

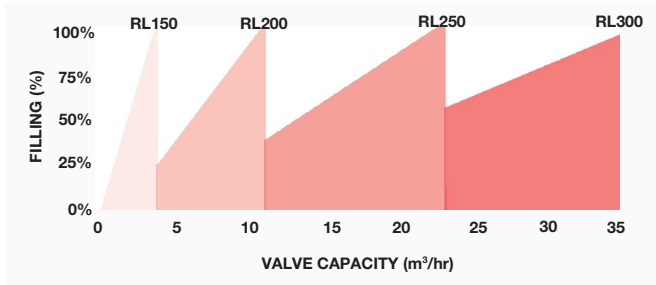

Anval can offer complete service and spare parts support to their valves and can work to achieve the optimum outcome for their equipment and maintenance needs.

Our products and solutions have proven themselves across a wide range of industries and in some of the most demanding manufacturing environments. We are proud to be the prescribed suppliers of valves for some of the world's biggest mining companies.

